

VIADRUS

VIADRUS HERCULES U 26 MANUAL FOR BOILER OPERATION AND INSTALLATION

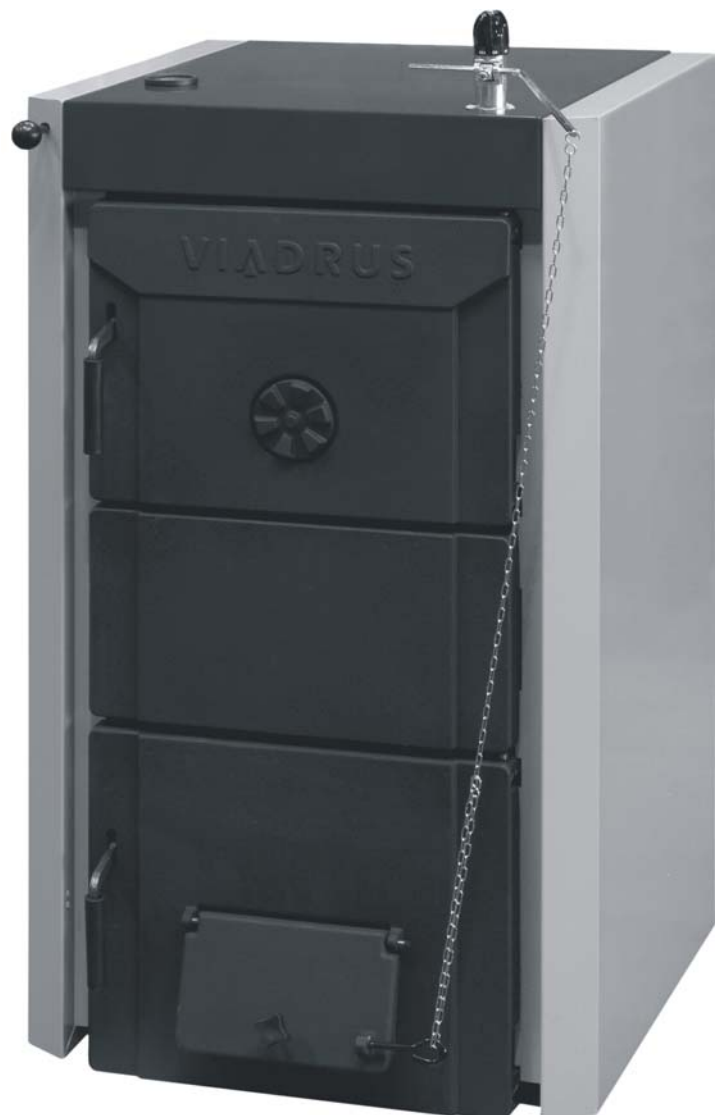

Table of contents:

page

1.	Boiler use and advantages	3
2.	VIADRUS HERCULES U 26 boiler technical data	3
3.	Description	6
3.1	Boiler construction	6
3.2	Regulation and safety elements	6
3.3	Equipment for surplus heat removal	9
3.4	Superfluous heat removal equipment- storage reservoirs	11
4.	Positioning and installation	12
4.1	Regulations and guidelines	12
4.2	Positioning possibilities	12
5.	Delivery and assembly	14
5.1	Delivery and accessories	14
5.2	Assembly procedure	15
5.2.1	Boiler drum installation	16
5.3.2	Boiler shells assembly	18
6.	Commissioning	22
6.1	Verification activities before commissioning	22
6.2	Boiler commissioning	22
7.	Boiler operation by user	22
8.	IMPORTANT WARNING	23
9.	Maintenance	24
10.	Instructions for product disposal after its lifetime extinction	24
11.	Guarantee and reliability for defects	25

Dear customer

We thank you that you have bought **VIADRUS HERCULES U 26**, a universal boiler thus having shown your confidence in **ŽDB GROUP a.s., VIADRUS division**.

For you to get used to a correct way of handling your new product from the beginning please read at first this manual for its usage (first of all the chapter no. 7 – Boiler operation by user and chapter no. 8 – **IMPORTANT WARNING**). Please follow the stated information whereby a longstanding and trouble-free boiler operation will be guaranteed to both your and our satisfaction.

VIADRUS HERCULES U 26 is a cast-iron sectional low-pressure boiler designated for combustion of:

- Solid fuels, coke, hard coal, wood
- Combustion of other materials like plastics is impermissible.

1. Boiler use and advantages

Three-sectional size of **VIADRUS HERCULES U 26** boiler is suitable for heat sources reconstructions in independent tenements, for smaller residential premises and leisure amenities. Bigger sizes of boilers meet the demands on heating the houses, shops, schools etc.

The boiler is manufactured in warm-water design with both natural and forced heating water circulation and working overpressure up to 400 kPa. Before dispatch the boiler is tested for tightness by applying 800 kPa overpressure.

The boiler is designated for heating both closed and open heating systems.

Boiler advantages:

1. A high lifetime of the cast-iron heat exchanger and all other parts with regard to the quality of used materials.
2. Long-term verified construction.
3. Sophisticated manufacturing technology on the automatic forming lines with a constant and verified quality of the manufacturing process. (ISO 9001, ISO 14 001).
4. Coke combustion efficiency 80%
5. Simple operation and maintenance.
6. Output graduation by the number of sections.

2. VIADRUS HERCULES U 26 boiler technical data

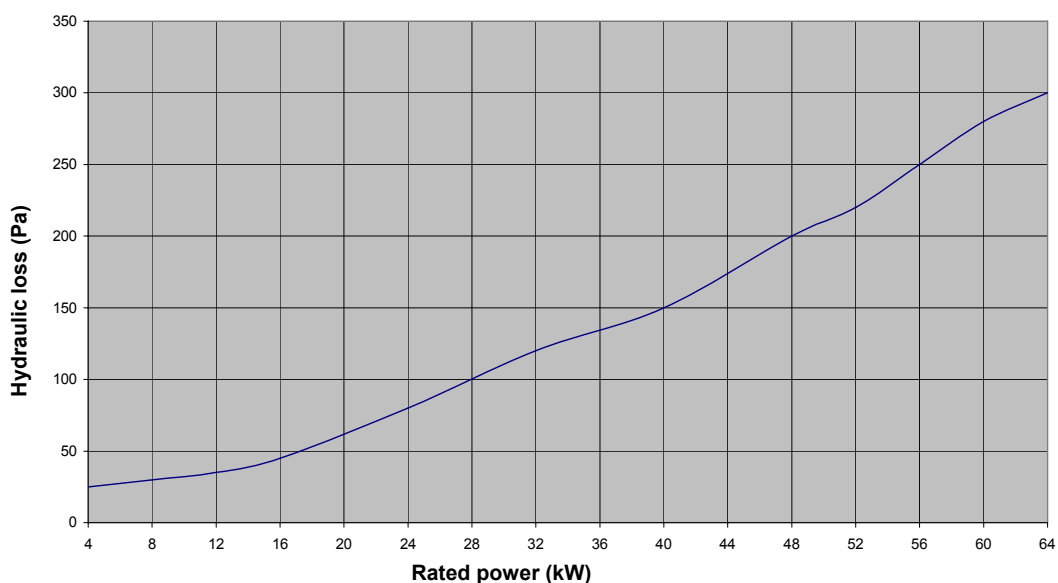

Fig. No. 1 Hydraulic loss of the boiler drum

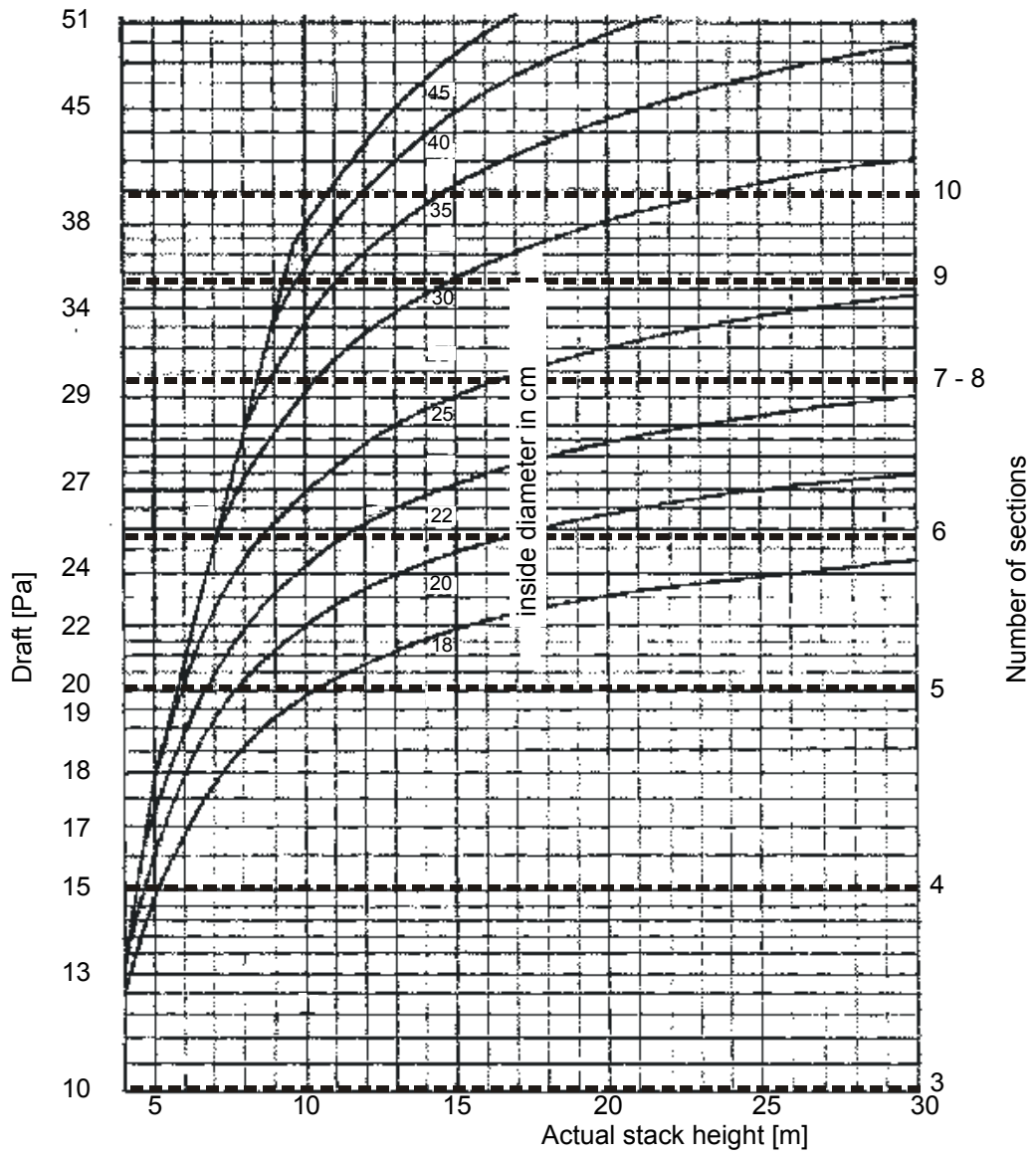

Fig. No. 2 Stack diameter setting

Tab. no. 1 Dimensions, technical parameters of boiler VIADRUS HERCULES U 26

Number of sections	pcs	3	4	5	6	7	8	9	10	
Boiler category according to EN 303 - 5	-	1								
Combustion chamber volume	dm ³	23	37	51	64,5	78	91,5	105	118,5	
Water space volume	l	27,6	33,3	35	44,7	50,4	56,1	61,8	67,5	
Weight	kg	218	258	298	348	398	448	498	548	
Combustion chamber depth	mm	185	295	405	515	625	735	845	955	
Diameter of smoke socket	mm	156					176			
Boiler dimensions: - height x width	mm	1218 x 600								
- depth	mm	643	754	865	976	1087	1198	1309	1420	
Filling hole dimensions	mm	300 x 320								
Maximum water operating overpressure	kPa	400								
Minimum water operating overpressure	kPa	50								
Water test overpressure	kPa	800								
Hydraulic loss	-	see Fig. No.1								
Minimum water inlet temperature	°C	60°C								
Recommended heating water operating temperature	°C	60 – 85								
Noise level	dB	Does not exceed the level 65 dB (A)								
Chimney draught	Pa	10	15	20	25	30	30	35	40	
Boiler connections - heating water		2"								
- reverse water		2"								
Maximum fuel weight in the chamber	kg	16,1	25,9	35,7	45,15	54,6	64,05	73,5	82,95	
Temperature of cooling water for safety after-cooling exchanger	°C	5 – 20								
Overpressure of cooling water for safety after-cooling exchanger	kPa	200 – 600								

Tab. no. 2 Dimensions, technical parameters –coke as fuel

granularity 24 – 60 mm, fuel moisture max. 15 % fuel efficiency: 26 - 30 MJ.kg⁻¹

Number of sections	pcs	3	4	5	6	7	8	9	10
Rated power	kW	15	22,5	30	37,5	43,5	50	56	63
Fuel consumption at the rated power	kg/h	2,43	3,64	4,86	6,07	7,04	8,09	9,07	10,2
Minimum output	kW	7,5	11,3	15	18,5	22,5	15	16,8	18,9
Fuel consumption at the minimum output	kg/h	1,21	1,83	2,43	3,0	3,64	2,43	2,72	3,06
Fuel efficiency	MJ.kg ⁻¹	27,8							
Burning time at the rated power	h	4							
Flue gases temperature at the rated power	°C	220-250							
Flue gases temperature at the minimum output	°C	120-180							
Flue gases mass flow rate at the minimum output	g/sec	3,53	5,33	7,08	8,73	10,6	7,08	8,2	11,2
Flue gases mass flow rate at the rated power	g/sec	7,08	10,6	14,15	17,69	21,2	24,4	27,3	30,7
Efficiency	%	80							

Tab. no. 3 Dimensions, technical parameters– hard coal as the fuel

granularity 24 – 60 mm, fuel moisture max. 15 % fuel efficiency: 26 - 28 MJ.kg⁻¹

Number of sections	pcs	3	4	5	6	7	8	9	10
Rated power	kW	11	16,5	22,5	31	39,5	45,5	51,5	58
Fuel consumption at the rated power	kg/h	1,87	2,8	3,82	5,26	6,7	7,72	8,73	9,83
Minimum output	kW	5,5	8,25	11,25	15,5	19,75	13,65	15,45	17,4
Fuel consumption at the minimum output	kg/h	0,93	1,4	1,9	2,63	3,35	2,32	2,62	2,95
Fuel efficiency	MJ.kg ⁻¹	28,31							
Burning time at the rated power	h	4							
Flue gases temperature at the rated power	°C	220 – 300							
Flue gases temperature at the minimum output	°C	120 – 190							
Flue gases mass flow rate at the minimum output	g/sec	4,295	6,445	8,78	12,105	15,43	6,66	7,53	8,616
Flue gases mass flow rate at the rated power	g/sec	8,59	12,89	17,56	24,21	30,86	22,2	25,1	28,72
Efficiency	%	75							

Tab. no. 4 Dimensions, technical parameters – wood as the fuel
fuel moisture max 20 % fuel efficiency: 14 – 18 MJ. kg⁻¹

Number of sections	pcs	3	4	5	6	7	8	9	10
Rated power	kW	8	15,75	23,5	28,25	33	35	40,5	46
Fuel consumption at the rated power	kg/h	2,56	5,04	7,52	9,03	10,55	11,19	12,95	14,71
Minimum output	kW	4	4,73	6,5	8,4	9,7	10,5	12,15	13,8
Fuel consumption at the minimum output	kg/h	1,28	1,51	2,08	2,69	3,1	3,36	3,89	4,41
Fuel efficiency	MJ.kg ⁻¹	15,01							
Burning time at the rated power	h	2							
Flue gases temperature at the rated power	°C	220 – 300							
Flue gases temperature at the minimum output	°C	120 – 190							
Flue gases mass flow rate at the minimum output	g/sec	1,796	2,870	3,950	4,670	5,380	5,124	5,929	6,735
Flue gases mass flow rate at the rated power	g/sec	5,99	9,59	13,18	15,58	17,97	17,96	19,76	22,45
Efficiency	%	75							

3. Description

3.1 Boiler construction

The main part of boiler is the cast-iron sectional boiler drum made of the grey cast-iron according to EN 1561, quality 150.

The pressure parts of boiler meet the demands on the strength according to:

EN 303-5 Heating boilers – Part 5: Heating boilers for solid fuels, hand and automatically stocked, nominal heat output of up to 300 kW – Terminology, requirements, testing and marking

The boiler drum is assembled of sections by means of pressed-in boiler insertions with 56 mm diameter and secured by anchor bolts. The sections create the combustion chamber and the ash pan space, the water space and the convective part. The heating water inlet and outlet are situated in boiler rear part.

The rear part of boiler in its upper part has a smoke extension/adapter and the heating water flange. In the lower part there is the reverse water flange. To the front section there are mounted the stoking and ash-pan doors. Under the ash-pan door there is installed a tilting grate.

The whole boiler drum is insulated by the health harmless mineral insulation which reduces the losses caused by heat transmission into the environment. The steel shell is coloured by a good quality comaxit spray.

3.2 Regulation and safety elements

The smoke shutter of the smoke extension/adapter regulates the flue gases outlet volume from the boiler into the chimney. It is operated by a handle with drawbar in the left upper part of boiler next to the stoking door.

The ash pan door choker regulates the combustion air inlet under the boiler grate. It is operated by a draught regulator. Another draught regulator (for 8, 9, 10 sectional boiler) regulates the rear choker. The regulator is set on the same temperature as the regulator in the front part of the boiler.

The stoking door choker serves for secondary air supply into the combustion chamber.

A combined device- the thermomanometer serves for heating water temperature and pressure detection in heating system. The reservoir of thermomanometer sensor is installed in upper part of the front boiler section.

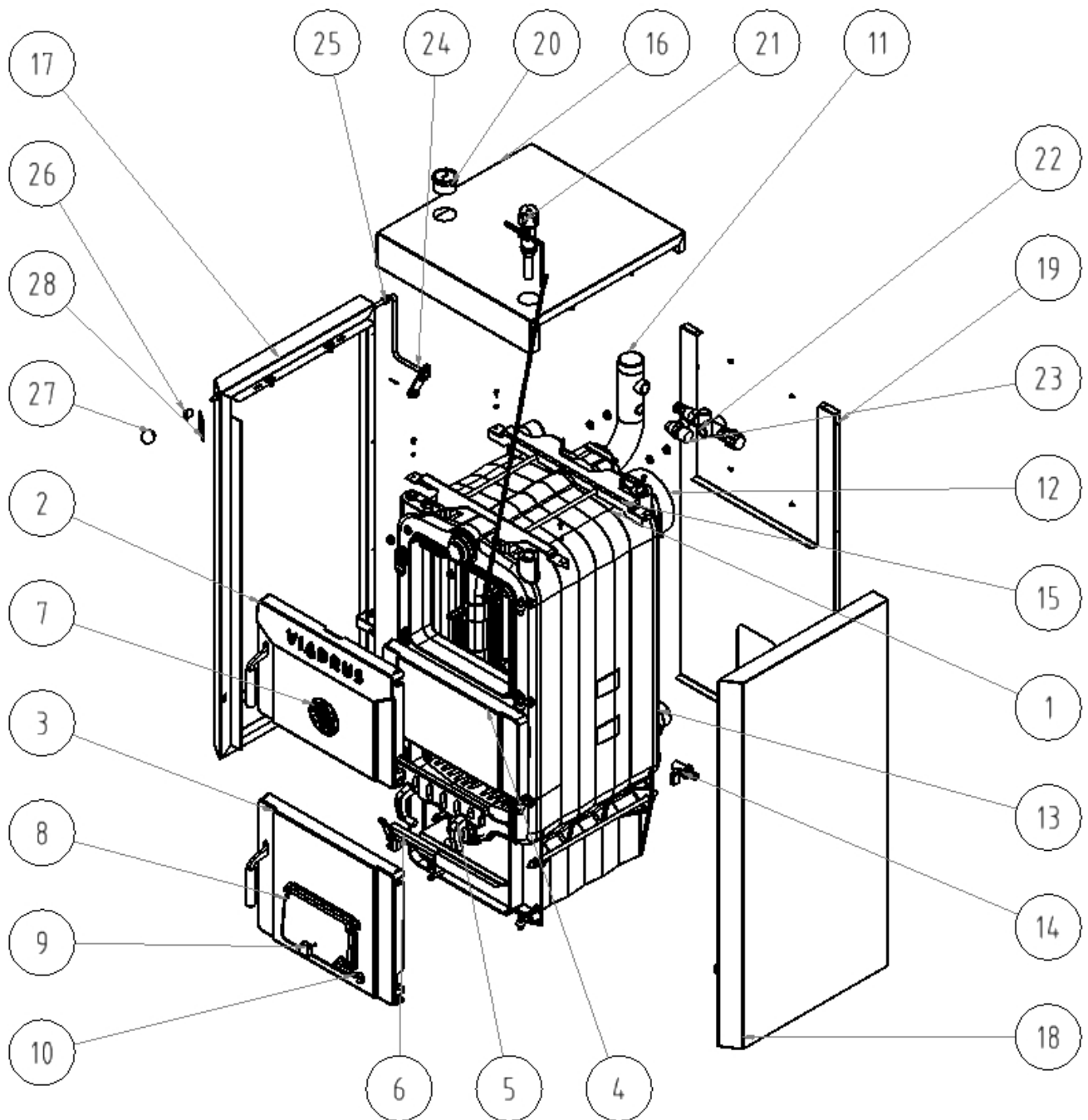

- | | |
|-------------------------------|--|
| 1. Boiler drum | 16. Upper part of the shell with insulation í |
| 2. Stoking door | 17. Left side part of the shell with insulation |
| 3. Ashpan door | 18. Right side part of the shell with insulation |
| 4. Middle part | 19. Rear part of the shell with insulation |
| 5. Tilting grate | 20. Thermomanometer |
| 6. Tilting grate holder | 21. Draught controller |
| 7. Rosette | 22. Two-way safety valve DVB 1 – 02 |
| 8. Choker | 23. Safety valve |
| 9. Choker screw | 24. Draw bar |
| 10. Suspension pin | 25. Bushing HEYCO |
| 11. Heating water flange | 26. Slant bushing |
| 12. Outlet neck | 27. Plastic ball |
| 13. Return water flange | 28. Label for smoke flap control |
| 14. Filling and draining cock | |
| 15. Lowered console | |

Fig. no. 3a) VIADRUS HERCULES U 26 3 – 7 sect. boiler assembly

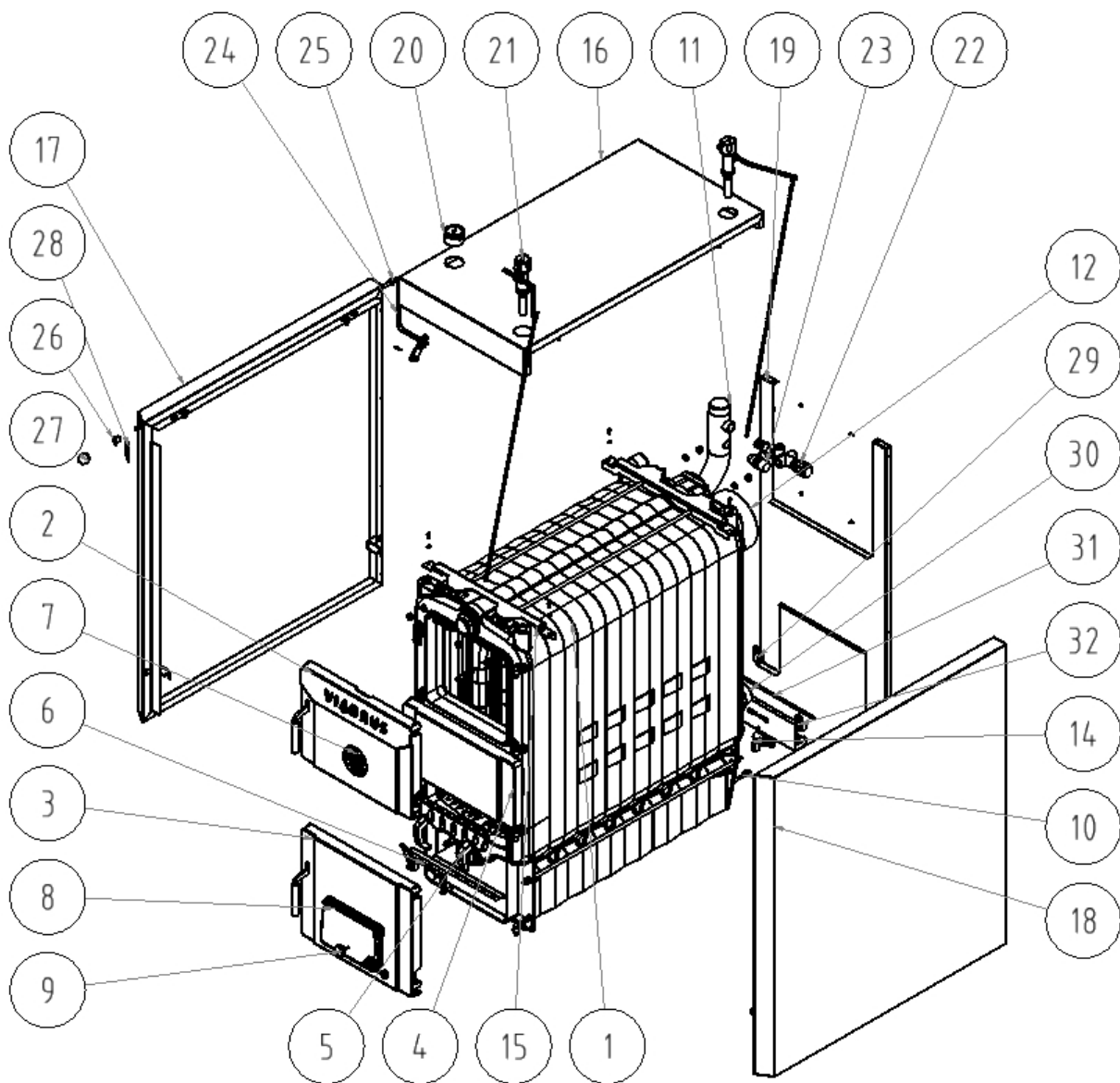

- | | |
|---|--|
| 1. Boiler drum | 17. Left side part of the shell with insulation |
| 2. Stoking door | 18. Right side part of the shell with insulation f |
| 3. Ashpan door | 19. Rear part of the shell with insulation |
| 4. Middle part | 20. Thermomanometer |
| 5. Tilting grate | 21. Draught controller |
| 6. Tilting grate holder | 22. Two-way safety valve DVB 1 – 02 |
| 7. Rosette | 23. Safety valve |
| 8. Choker | 24. Draw bar |
| 9. Choker screw | 25. Bushing HEYCO |
| 10. Suspension pin | 26. Slant bushing |
| 11. Heating water flange | 27. Plastic ball M10 |
| 12. Outlet neck | 28. Label of smoke flap control |
| 13. Return water flange | 29. Left choker console for the rear section |
| 14. Filling and draining cock | 30. Choker for the rear section |
| 15. Lowered console | 31. Choker axis for the rear section |
| 16. Upper part of the shell with insulation | 32. Right choker console for the rear section |

Fig. no. 3b) VIADRUS HERCULES U 26 8 – 10 sect. boiler assembly.

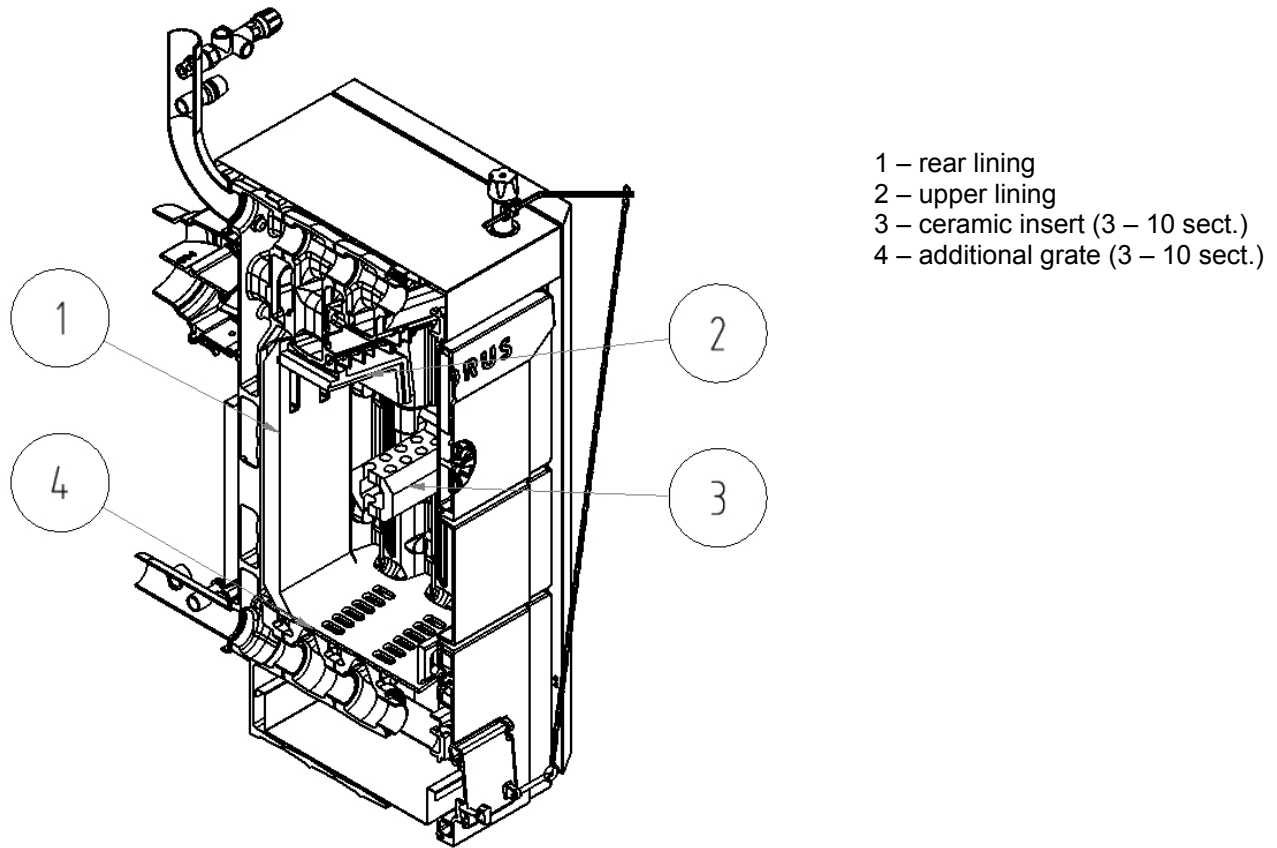

- 1 – rear lining
- 2 – upper lining
- 3 – ceramic insert (3 – 10 sect.)
- 4 – additional grate (3 – 10 sect.)

Fig.no.3c) Diagram of VIADRUS HERCULES U 26 boiler - location of additional equipment

3.3 Equipment for surplus heat removal

The after-cooling loop or the two way safety vent DBV 1 - 02 serves for surplus heat removal in case the water temperature in boiler exceeds 95 °C.

The after-cooling loop is connected to the boiler flanges according to Fig. No. 4, the two way safety vent according Fig. No. 6.

In case of boiler overheating (the output water temperature exceeds 95 °C) the thermostatic valve switches on and the superfluous heat is led off via an after-cooling loop.

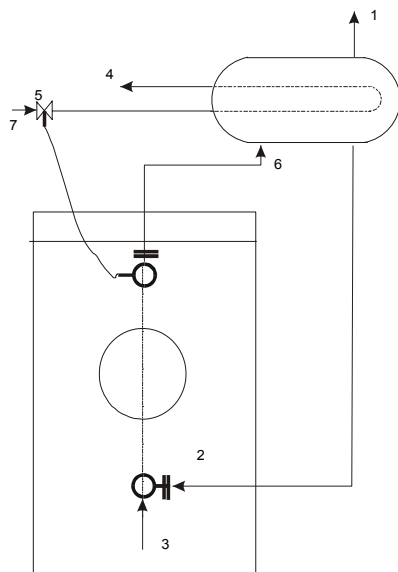

- 1 – Heating water outlet into the system 2"
- 2 – Reverse water inlet from the after-cooling loop 1 1/2 "
- 3 – Reverse water inlet into the boiler from system 2"
- 4 – Cooling water outlet
- 5 – Thermostatic valve TS 130 (STS 20)
- 6 – Heating water outlet from boiler 2 "
- 7 – Cooling water inlet

Fig. No. 4 Hydraulic chart of after-cooling loop connection

In case the system is equipped with a two way safety vent and the boiler becomes overheated (the output temperature exceeds 95 °C) the two way safety vent creates a cold water circuit which is kept until the temperature drops below the limit temperature. At this moment there are simultaneously closed the discharge cooling equipment and the cold water inlet of refilling the system.

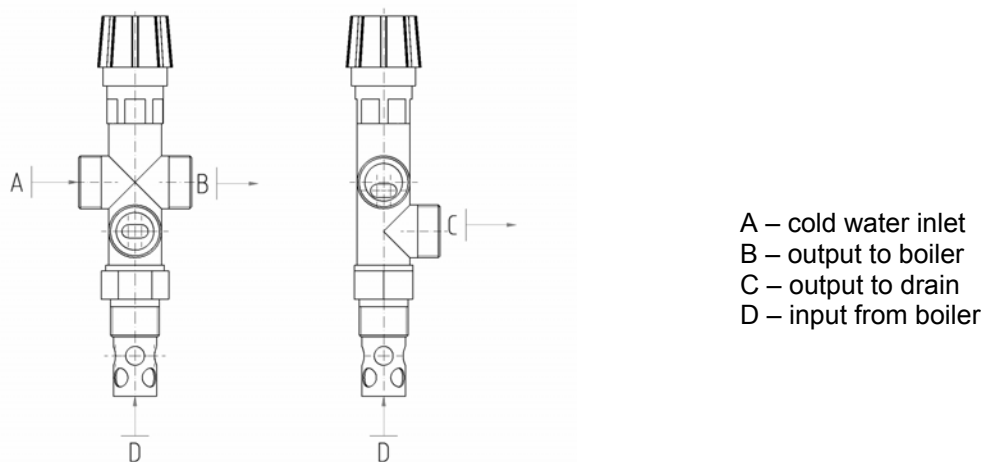
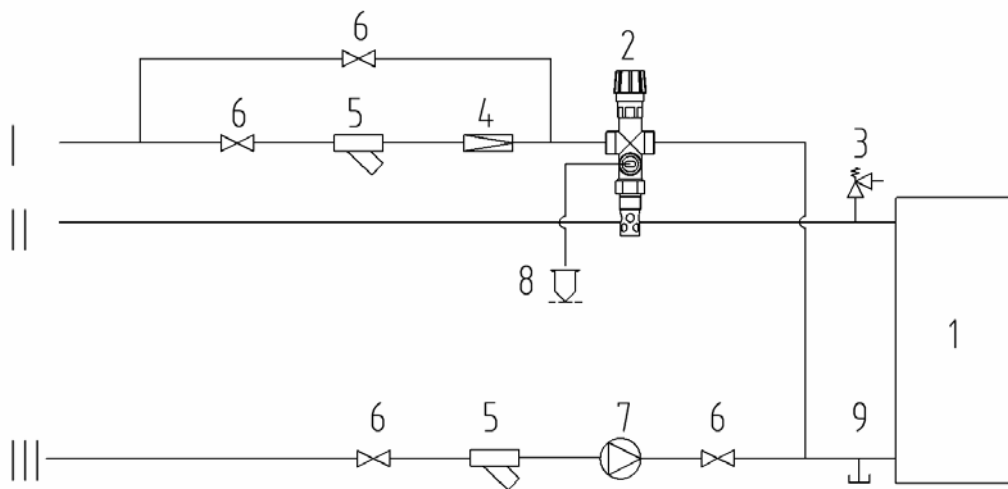

Fig. No. 5 The two way safety vent DVB 1 - 02



- 1 – Boiler
- 2 – Two way safety vent DBV 1 – 02
- 3 – Safety valve
- 4 – Transforming valve
- 5 – Filter
- 6 – Ball-shaped cock
- 7 – Pump
- 8 – Surplus heat removal
- 9 – Bleed valve
- I – Cooling water inlet
- II – Heating water outlet
- III – Return water inlet

Fig. No. 6 The recommended scheme of the two way safety vents DBV 1 – 02 connection

It is necessary to install a safety valve for maximum overpressure of 400 kPa on the system and its dimension must correspond to the rated boiler output. The safety valve must be located directly behind the boiler. Any stop valve must not be located between the safety valve and boiler. If you have any questions, please contact our contractual assembly firm and service organizations.

The two way safety vent DBV 1 – 02 technical data (from the firm Regulus)

Opening temperature (limit):	100 °C (+0° - 5 °C)
Maximum temperature:	120 °C
Maximum stress on boiler side	400 kPa
Maximum stress on water side	600 kPa
Nominal flow at Δp 100 kPa:	1,9 m ³ /h

Usage

The two way safety vent DBV 1 – 02 is used as a protection of heating boilers against overheating. In the valve body there is the bleed and supply valve controlled by thermostatic element. When the limit temperature is reached, the bleed and supply valve is simultaneously opened meaning that the cold water is running in and the hot water is running out. When the temperature drops below limit, the bleed and supply valve is simultaneously closed.

Caution! It is not a compensation for safety valve.

In case of two way safety vent reaction, when there is a possibility of boiler having been filled with the water, which does not meet the ČSN 077401 requirements it is necessary to change the water in the heating system so that it meets the ČSN 077401 requirements again.

Installation

Installation can be only carried out by a qualified person. For the correct operation of the thermostatic, two ways safety vent it is necessary to comply with the conditions for its installation and keep the flow directions marking on its body. The safety vent is always mounted in the output pipe of boiler or directly on the upper part of boiler, where the hot water leaves boiler and is transported into heating system. When installing the vent it is necessary to check, if the 3/4" socket usage, which can be both in pipeline and on boiler, ensures complete immersion of the thermostatic vent element after the vent installation. After the vent has been installed in socket, connect the down pipe, in which the hot water from boiler will flow to drain, to „C“ (see. fig. No. 5). The cooling water inlet, which will cool the boiler after setting the vent in operation, is connected (see fig. No. 6) to „A“ (see fig. No. 5). The filter for mechanical impurities must be installed in the cooling water inlet. It is necessary to connect the pipeline to „B“ (see. fig. No. 5) and the pipeline is to be led into reverse flow pipe of heating system near the boiler (see fig. No. 6).

Regular maintenance

Once a year it is necessary to turn the safety vent's head to remove possible impurities formed in the vent. Clean the cooling water inlet filter.

In case of using an open expansion tank it is not necessary to use a protecting device against overheating.

Every heat source in an open heat system must be connected with an open expansion tank positioned at the highest point of the heat system. The expansion tanks must be rated in the way that they can contain the changes in water volume resulting from heating and cooling.

The open expansion tanks must be equipped with non-closable bleeder and a overflow pipes. The overflow pipe must be designed in the way that it safely drains off the maximum flow volume entering the system. This can be achieved by rating the overflow pipes by one DN higher than that of the filling piping. The expansion tanks and their connecting pipes must be designed and positioned in the way that freezing is reliably inhibited.

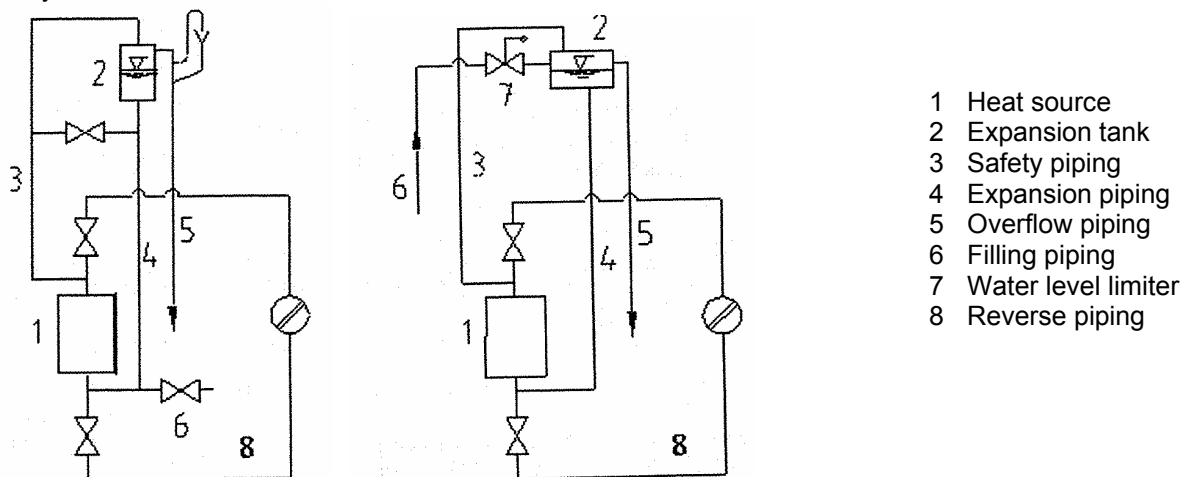

Fig. no. 7 The examples of open expansion tanks connection

3.4 Superfluous heat removal equipment- storage reservoirs

In case that the required volume exceeds 300 l we recommend to install a storage reservoir.

Because the minimum output of this boiler is higher than 30% of the rated power we recommend to remove the heat into the storage reservoirs.

The calculation of the minimum volume of stack heat exchanger

$$V_{sp} = 15T_b \times Q_N (1 - 0,3 \times (Q_H/Q_{min}))$$

where

V_{sp} the volume of storage reservoir in l
 Q_N rated thermal output in kW
 T_b burning time in h

Q_H thermal load of buildings in kW
 Q_{min} minimum thermal output in kW

The dimensions of storage reservoirs at the boilers for central heating that are operated with individual prescribed fuels must be set according to the fuel which needs the biggest storage reservoir. This storage reservoir isn't necessary if the calculated volume is smaller than 300 l.

4. Positioning and installation

4.1 Regulations and guidelines

The solid fuel boiler can only be installed by a firm holding a valid licence to carry out its installation and maintenance. A project according to the valid regulations must be elaborated for installation. Before the boiler installation on an older heating system the installation firm must flush out(clean) the whole system. **The heating system must be filled with water meeting the ČSN 07 7401 requirements; especially its hardness must not exceed the required parameters**

Tab.no.4

Recommended values		
Hardness	mmol/l	1
Ca ²⁺	mmol/l	0,3
The total Fe + Mn concentration	mg/l	(0,3)*

*) recommended value

WARNING!!! The use of anti-freeze mixture is not recommended by the manufacturer.

In case of two way safety vent reaction, when there is a possibility of boiler having been filled with the water, which does not meet the ČSN 077401 requirements it is necessary to change the water in the heating system so that it meets the ČSN 077401 requirements again.

a) to the heating system

- ČSN 06 0310 Heating systems in buildings – Designing and installation
- ČSN 06 0830 Heating systems in buildings – protecting device
- ČSN 07 7401 Water and steam for thermal energy equipments with working pressure up to 8 MPa
- EN 303-5 Heating boilers – Part 5: Heating boilers for solid fuels, hand and automatically stocked, nominal heat output of up to 300 kW – Terminology, requirements, testing and marking

b) to the chimney

- ČSN 73 4201 Chimneys and flue gas ducting – designing, implementation and connection of fuel consumers.

c) regarding the fire regulations

- ČSN 06 1008 Fire safety of heat installations.
- EN 13501-1 Fire classification of construction products and building elements – Part 1: Classification using test data from reaction to fire tests.

d) to the system of HWS heating

- ČSN 06 0320 Heating systems in buildings – Hot water preparation – Designing and planning
- ČSN 06 0830 Heating systems in buildings – Safety devices.
- ČSN 73 6660 House water plumbing

4.2 Positioning possibilities

VIADRUS HERCULES U 26 boiler is approved for installation in non-residential premises (like cellars, corridors etc.).

The boiler positioning with regard to the fire regulations:

1. Installation on a floor made of incombustible material (Fig. No. 8)
 - The boiler can be installed on a fireproof floor exceeding the boiler platform by 20 mm on the sides and only up to the boiler drum depth.
 - If the boiler is positioned in a cellar we recommend to install it on a retaining wall (substruction) minimum 50 mm high
 - install the boiler in the middle of the retaining wall
2. A safe distance from the combustible materials
 - When installing and operating the boilers it is necessary to keep a safe distance from combustible materials with combustibility degrees B, C₁ a C₂ (according to ČSN 06 1008) according to regulation 84/1997 (the distance is shown in Appendix).
 - For easily flammable materials with combustibility degree C₃, which burn quickly and by themselves also after the ignition source removal (like paper, millboard, stiff paper, asphalt and tar boards, wood and fibreboards, plastics, flooring materials) the safe distance is doubled (the distance is shown in Appendix).
 - The safe distance is to be doubled also in case that the combustibility degree of building material wasn't proved. (the distance is shown in Appendix).

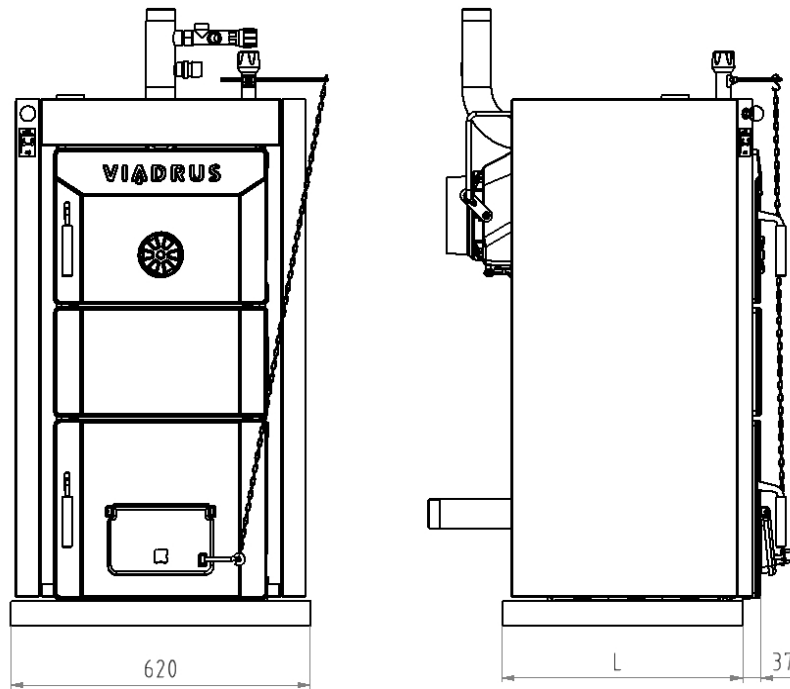

number of sections	3	4	5	6	7	8	9	10
L mm]	387	498	609	720	831	942	1053	1164

Fig. No. 8 Substruction (retaining wall) dimensions

Tab. no. 5 Combustibility degrees of building materials and products

Combustibility degrees of building materials and products	Building materials and products ranked in combustibility degrees (abstract from EN 13 501-1)
A – incombustible	Granite, sandstone, concrete, bricks, ceramic tiles, mortars, fireproof plasters, ...
B – combustible with difficulty	acumin, izumin, heraklit, lignos, boards and basalt felt, fibreglass boards, ...
C ₁ – hardly combustible	Beech and oak wood, hobrex boards, plywood, werzalit, umakart, sirkolit, ...
C ₂ – medium combustible	Pinewood, larch, whitewood, chipboard and cork boards, rubber flooring, ...
C ₃ – easily combustible	Asphaltboard, fibreboards, cellulose materials, polyurethane, polystyrene, polyethylene, PVC, ...

Boilers positioning with regard to the necessary handling space:

- Basic AA5/AB5 environment according to ČSN 33 2000-3.
- In front of the boiler there must be left a minimum handling area of 1000 mm.
- Keep minimum 400 mm distance between the rear part of the boiler and the wall.
- At least from one lateral face keep minimum 400 mm space for access to rear part of the boiler.

Fuel storage:

- **Dry fuel has to be used for a proper combustion in the boiler. The manufacturer recommends fuel storage in cellars or at least under shelter.** It is out of question to store the fuel behind the boiler or next to the boiler within a distance smaller than 400 mm.
- It is out of question to store the fuel between two boilers in the boiler room.
- The manufacturer recommends to keep minimum 1000 mm distance between the boiler and the fuel or to store the fuel in a room different from that where the boiler is installed.

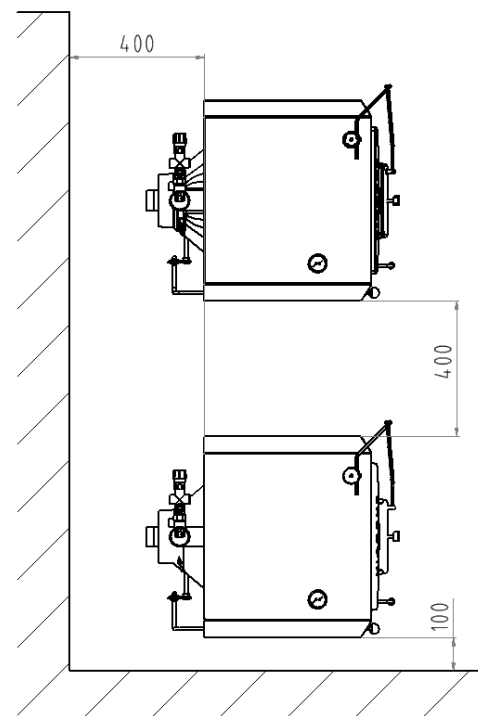

Fig.no.9 Location of boilers in the boiler room

5. Delivery and assembly

5.1 Delivery and accessories

VIADRUS HERCULES U 26 is delivered according to the purchase order on the pallet on which the complete boiler drum is placed and on the side there is attached the wrapped boiler shell. The accessories are put inside the boiler drum, accessible only after opening the stoking door. The boiler is wrapped in a transport package and it must not be tilted over during the transport.

Standard boiler delivery

- Boiler on a pallet, with an adequate number of sections
 - boiler heating water flange with a thread (curved) 1 pc
 - reverse water flange (3 – 7 sect.) 1 pc
 - reverse water flange with distribution tube (8 – 10 sect.) 1 pc
 - sealing ϕ 90 x 60 x 3 2 pcs
 - washer 10,5 8 pcs
 - nut M10 8 pcs
 - filling and discharge tap Js 1/2" 1 pc
 - draught regulator complete (3 – 7 sect.) 1 pc
 - draught regulator complete (8 – 10 sect.) 2 pcs
 - suspension pin (8 – 10 sect.) 1 pc
 - Js 6/4" blinding plug 1 pc
 - sealing ϕ 60 x 48 x 2 1 pc
- The shell incl. the ash pan, adequately sized incl. insulation
 - lowered console 2 pc
 - washer 10,5 4 pcs
 - nut M10 4 pcs
 - spring clip 4 pcs
 - screwM5 x 12 4 pcs
 - washer 6,4 4 pcs
 - bushing HEYCO SB – 625 – 8 1 pc
 - slant bushing 1 pc
 - screwST 4,2 x 9,5 10 pcs
 - connecting plug 4 pcs
 - thermomanometer 1 pc
- Draw bar 1 pc
 - lock 2,5 x 32 1 pc
 - plastic ball M10 1 pc
- Smoke shutter operation label 1 pc
- Choker screw 1 pc
- Cleaning tools
 - hook 1 pc
 - brush with a handle 1 pc
 - spike 1 pc
 - straight rivet with a thread 2 pcs
 - dowel 8 mm 2 pcs
- Handling key 1 pc
- Commercial& technical documentation

Supplementary outfit (is not included in delivery):

- ceramic plate for hard coal combustion 1 pc
- rear lining for wood combustion **for 8 – 10 sections** 1 pc
- auxiliary grate for wood combustion 2 pcs according to the size
- upper lining for wood combustion **for 8 – 10 sections** (8 sect.-10 pcs, 9 sect.-12 pcs, 10 sect.-14 pcs)

Necessary accessories: (is not included in delivery):

- After-cooling loop (1 pc) (for the 3 – 7 sectional boiler) incl. flange or the two way safety vent DBV 1 - 02 (for the 3 – 10 sectional boiler) incl. siseal 10 g. This equipment needn't be used in case of an open heating system.
- Thermostatic valve TS 130 (STS 20) – TV 95°C – can be delivered directly from the wholesale (only at the delivery with after-cooling loop)
- Safety valve 1 pc

By request (is not included in delivery):

- Filter 3/4" – for delivery with the two way safety vent DBV 1 - 02

The supplementary outfit, necessary accessories and optional boiler accessories is not included in the boiler standard price.

5.2 Assembly procedure

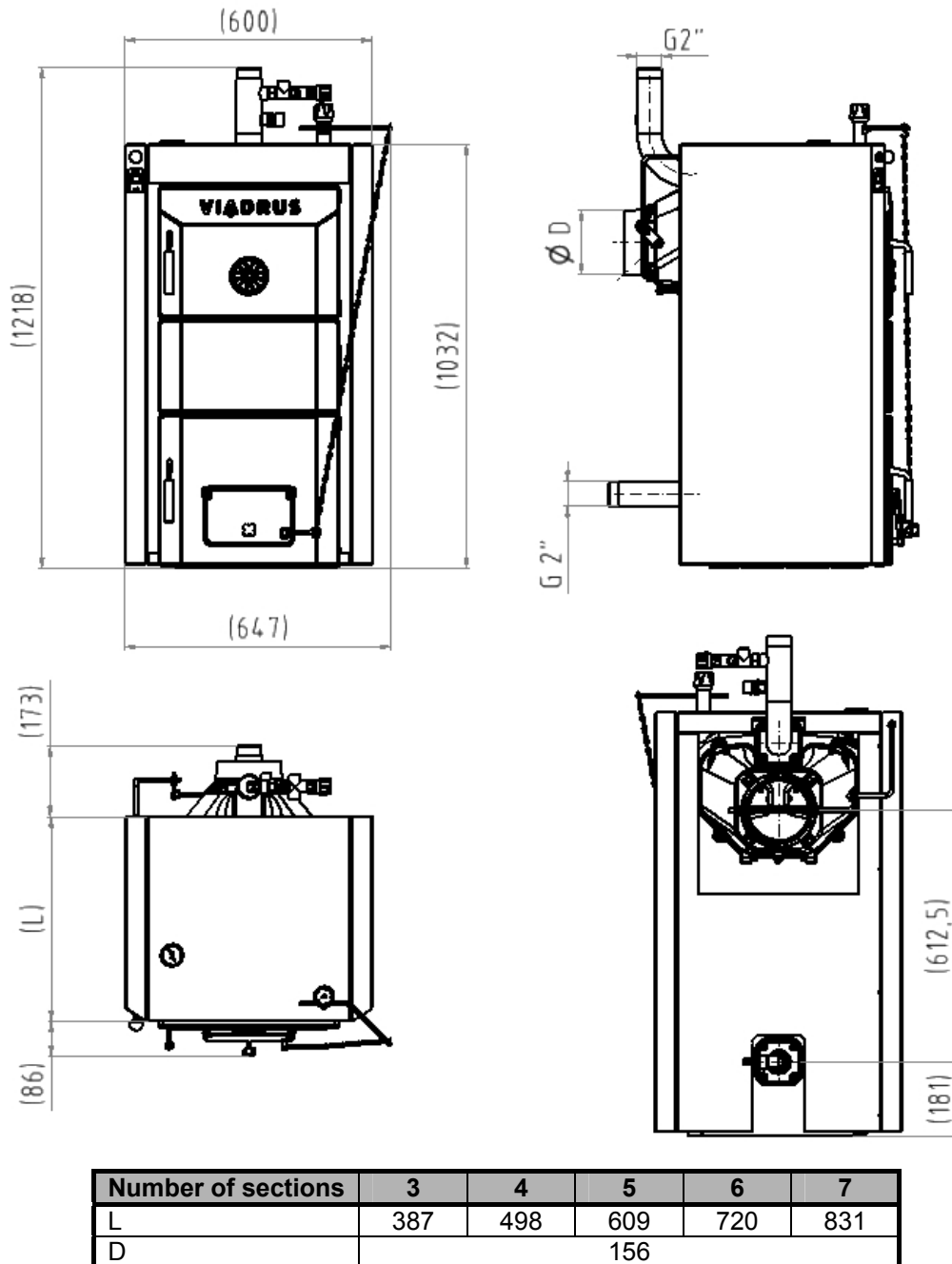

Fig.no.10a) Connecting dimensions of VIADRUS HERCULES U 26 3 – 7 sect. boiler

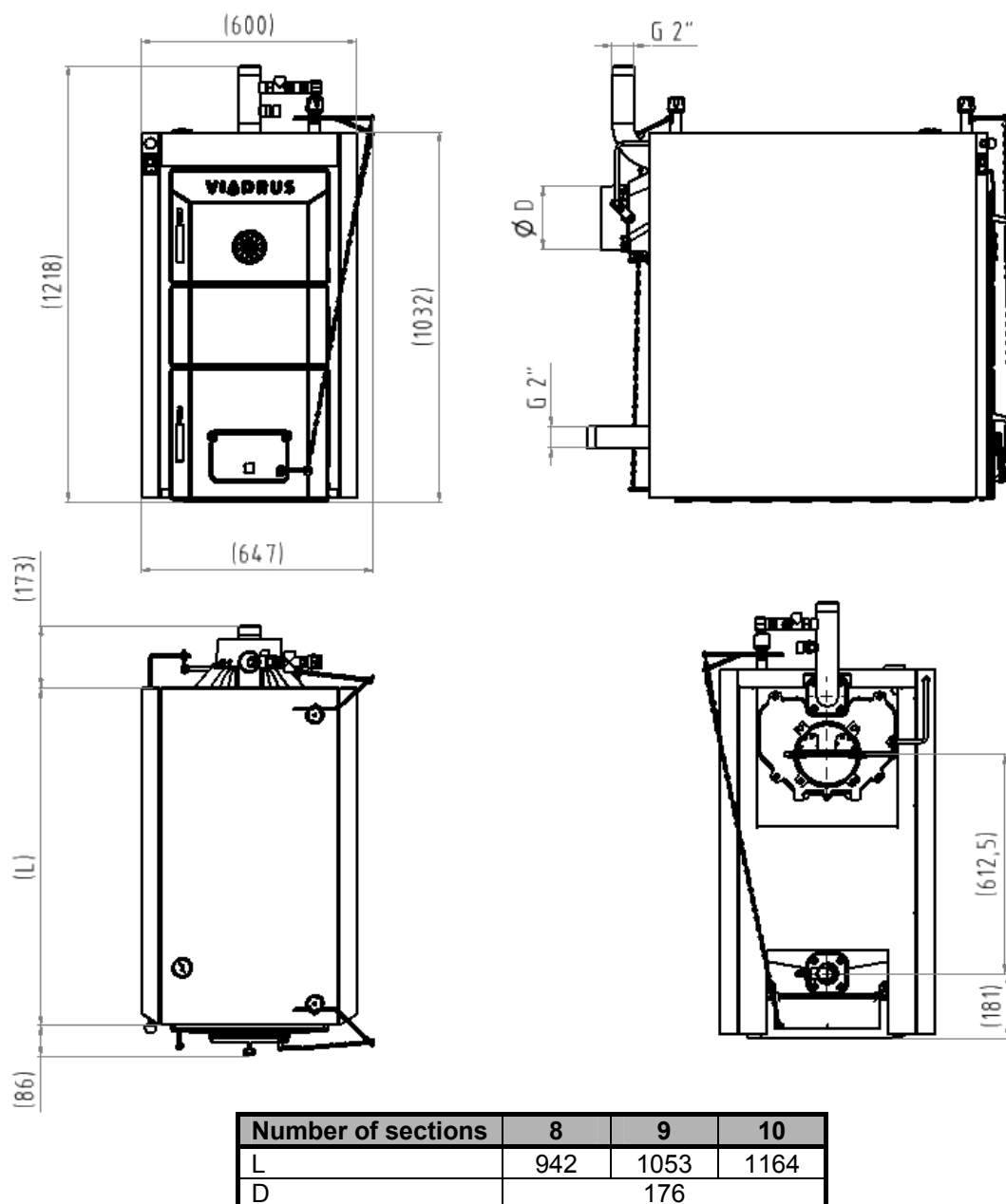

Fig. no. 10b) Connecting dimensions of VIADRUS HERCULES U 26 8 – 10 sect. boiler.

5.2.1 Boiler drum installation

Boiler drum installation- after-cooling loop

1. Set the boiler drum on the retaining wall (substruction)
2. On the weldment of after-cooling loop weld in advance the after-cooling loop heating water flange (according to the boiler room layout), insert the sealing $\varnothing 90 \times 60 \times 30$ between the flange and the boiler, then mount the weldment to the boiler by means of 4 pcs nut M 10 and 4 pcs washer 10,5. The upper outlet of heating water interconnect with the heating system by means of a weld.
3. Interconnect the lower outlet from the after-cooling loop by welding a 1 1/2" tube with reverse water outlet (reverse water flange) to the boiler.
4. Mount the thermostatic valve on one of after-cooling loop outlets (mount the sensor into the reservoir and connect the cold water inlet 1/2") mind the flow direction marked by an arrow; it must correspond to that shown in Fig. No. 4.
5. Other 1/2" outlet from the after-cooling loop interconnect with the drain (warning: for the check of thermostatic valve function we recommend to interconnect the water outlet with the drain by means of a funnel.)
6. After the boiler connection to the heating system screw a filling and discharge taps to the rear section according to Fig. No. 11

7. To the smoke extension (adapter) set the smoke tube and insert into the chimney opening. The smoke tube diameter is 160 mm for the sizes with 3 – 7 sections, 180 mm for 8 – 10 sections.
8. Screw the draught regulator into the opening in upper part of the front section. The boiler draught regulator adjustment procedure is shown in manual enclosed to particular regulator. For the 8 – 10 sectional boiler screw two draught regulators according to Fig. No. 3.
9. Blind the threaded opening JS 6/4" in the front section with JS 6/4" plug. Insert the sealing Ø 60 x 48 x 2 under the plug.
10. It is recommended to use shut-off valves for heating water inlet and outlet since without the valves it will be necessary to drain the whole system during the filter cleaning.

Boiler drum installation – the two way safety vent DBV 1 - 02

1. Set the boiler drum on the retaining wall (substruction)
2. Insert the sealing Ø 90 x 60 x 30 between the heating water flange and the boiler, then mount to the boiler by means of 4 pcs nut M 10 and 4 pcs washer 10,5 (according to the boiler room layout). By welding connect the upper heating water outlet with heating system.
3. Insert the sealing Ø 90 x 60 x 30 between the reverse water flange (at the 8 – 10 sectional boiler the reverse water flange with distribution tube) and the boiler, then mount by means of 4 pcs nut M 10 and 4 pcs washer 10,5 to the boiler. By welding connect the lower heating water outlet with heating system.
4. According to Fig. no. 6 interconnect the two-way safety valve DBV 1 – 02 with the flange of the return and heating water (the return water flange with a distribution pipe at the version with 8-10 sections) and with cooling water inlet plus superfluous heat outlet.
5. Mount the discharge valve in the return water flange.
6. Set the smoke tube to the smoke extension/adapter and insert into the chimney opening. The smoke tube diameter is 160 mm for sizes 3 – 7 sections, 180 mm for 8 – 10 sections.
7. Screw the draught regulator into the opening in the upper part of the front section and the upper part of the rear section. The chimney draught regulator adjustment is shown in manual enclosed to particular regulator. For the 8 – 10 sectional boiler screw two draught regulators according to Fig. No. 3.
8. Blind the threaded opening JS 6/4" in the front section with JS 6/4" plug. Insert the sealing Ø 60 x 48 x 2 under the plug.
9. It is recommended to use shut-off valves for heating water inlet and outlet since without the valves it will be necessary to drain the whole system during the filter cleaning.

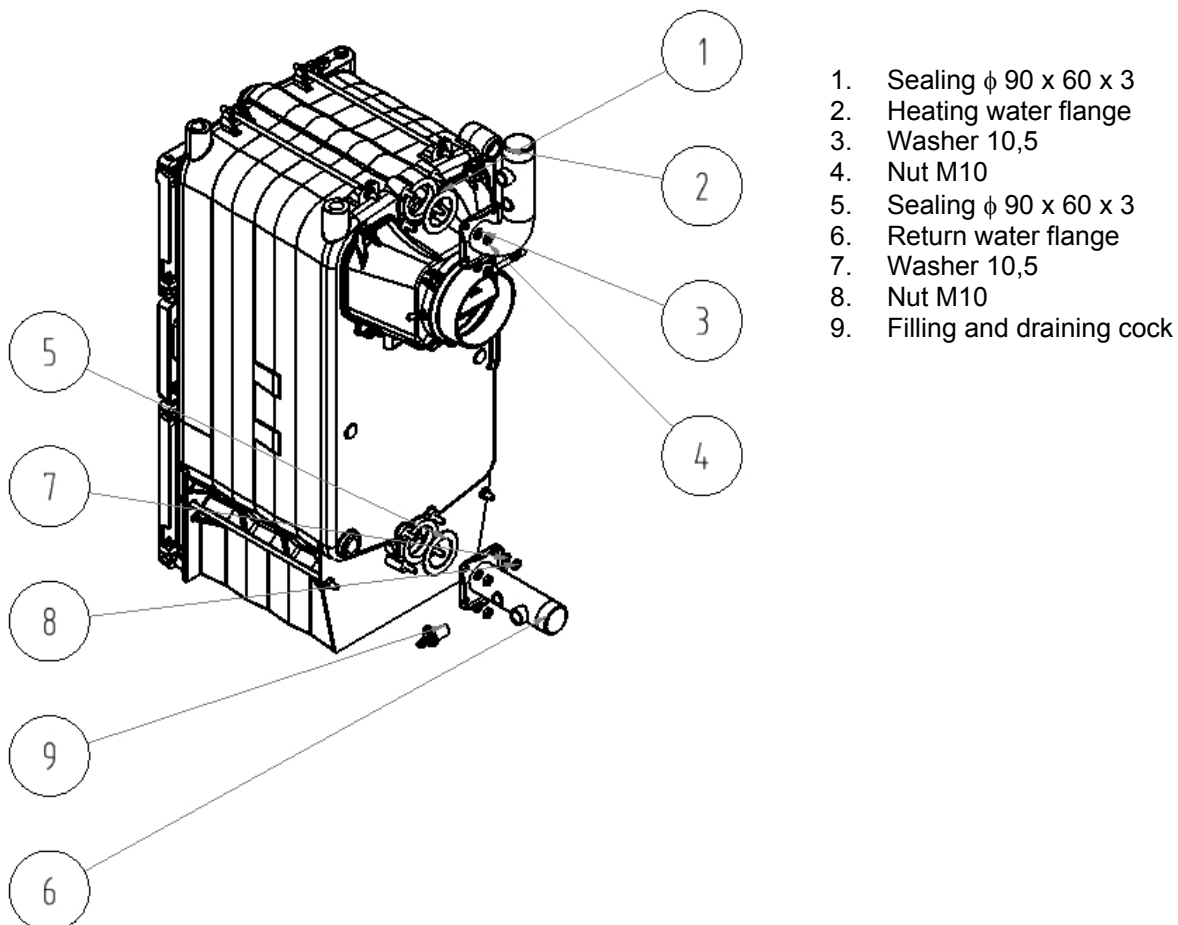

Fig.no.11 Boiler drum installation

5.3.2 Boiler shells assembly

1. Take the shells out of the cardboard cover.
2. Put two lowered consoles(1) on the threads of upper anchor bolts and screw them by means of four nuts M10 (3) and four washers 10,5 (2) - (see Fig.no.12).

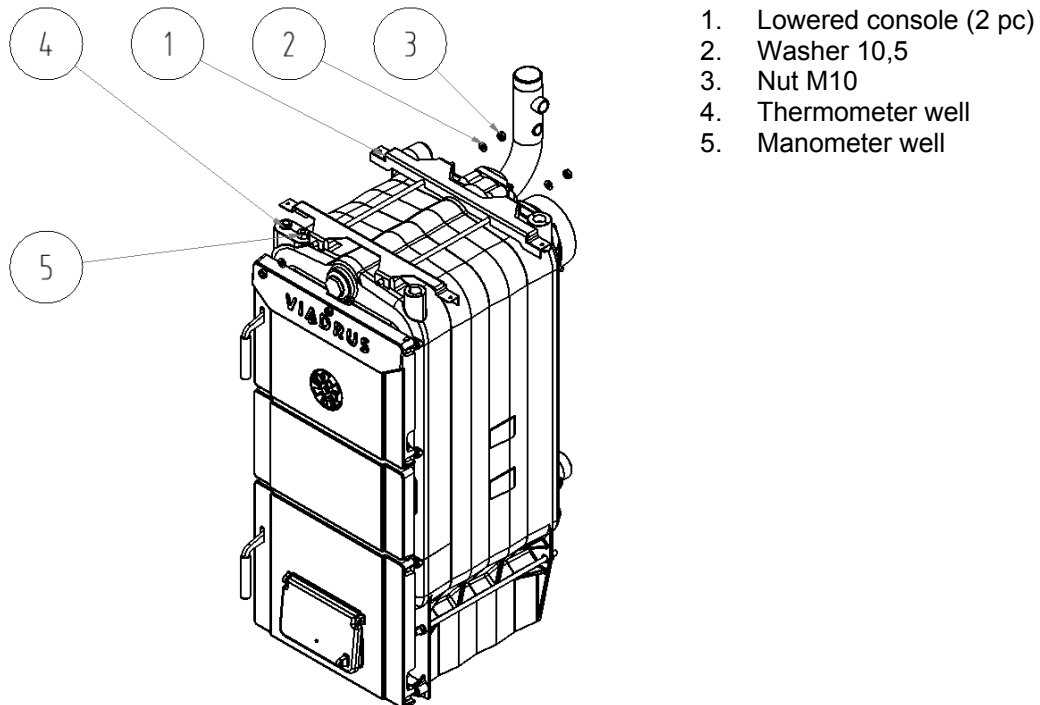

Fig.no.12 Mounting of boiler shell consoles

3. Mount two spring clips (2) on the right side part of the shell (1), then insert the insulation (see Fig.no.13). Put the boiler shell on the lower anchor bolts and connect the upper part with the lowered consoles by means of two screws M5 x12 and two washers 6,4 (see Fig.no.16).

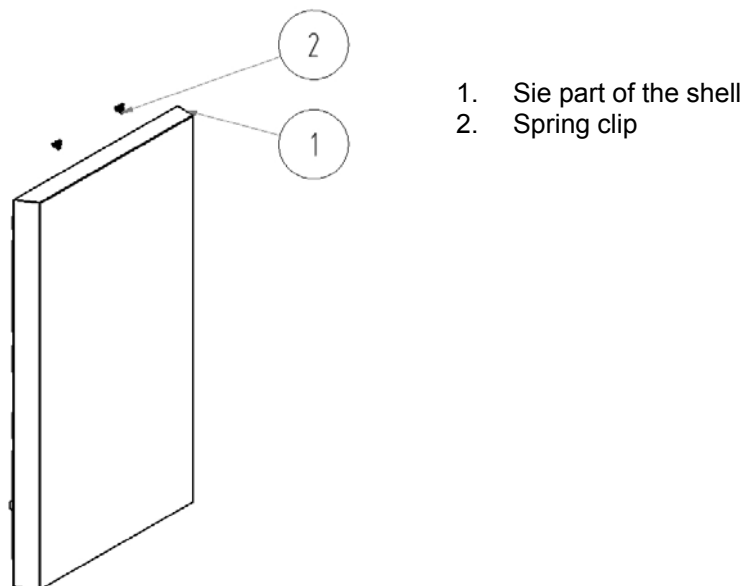
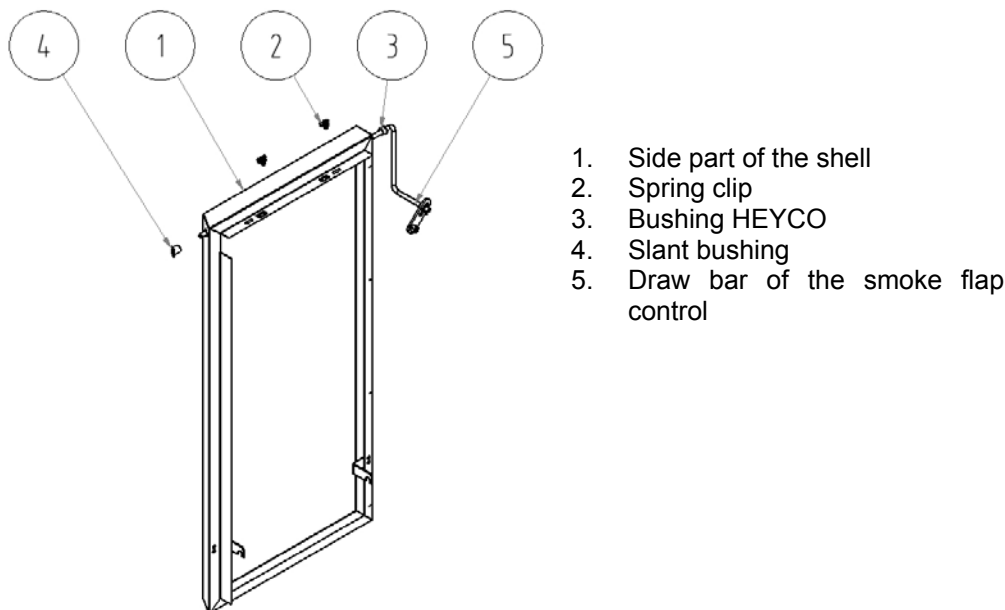

Fig.no.13 Right side part of the shell

4. Mount two spring clips (2) on the left side part of the shell (1), insert the bushings (3, 4), then insert the draw bar of smoke flap control (5) and the insulation (see Fig.no.14). Put the shell on the lower anchor bolts and connect the upper part with the lowered consoles by means of two screws M5 x12 and two washers 6,4 (see Fig. no. 16).
5. Mount the insulation on the rear part of the shell (10 – Fig.no.16) and screw it to the side parts of the shell by means of the screws ST 4,2 x 9,5 (11 – Fig.no.16).



1. Side part of the shell
2. Spring clip
3. Bushing HEYCO
4. Slant bushing
5. Draw bar of the smoke flap control

Fig.no.14 Left side part of the shell

5. Mount four connecting plugs (2) on the upper part of the shell (1) and insert the thermomanometer (8 – Fig. no. 16).
6. Insert the thermometer sensor into the thermometer well (4 – Fig.no.12) and screw the manometer into the manometer well (5 – Fig.no.12).
7. Insert the insulation into the upper part of the shell and put it on the side parts of the shell.
8. Screw the rear part of the shell to the upper part of the shell by means of two screws ST 4,2 x 9,5 (11 – Fig. no. 16).

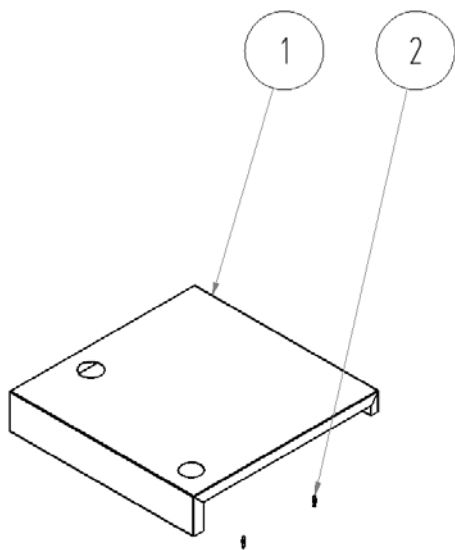

1. Upper part of the shell
2. Connecting plug

Fig. no. 15 Upper part of the boiler shell

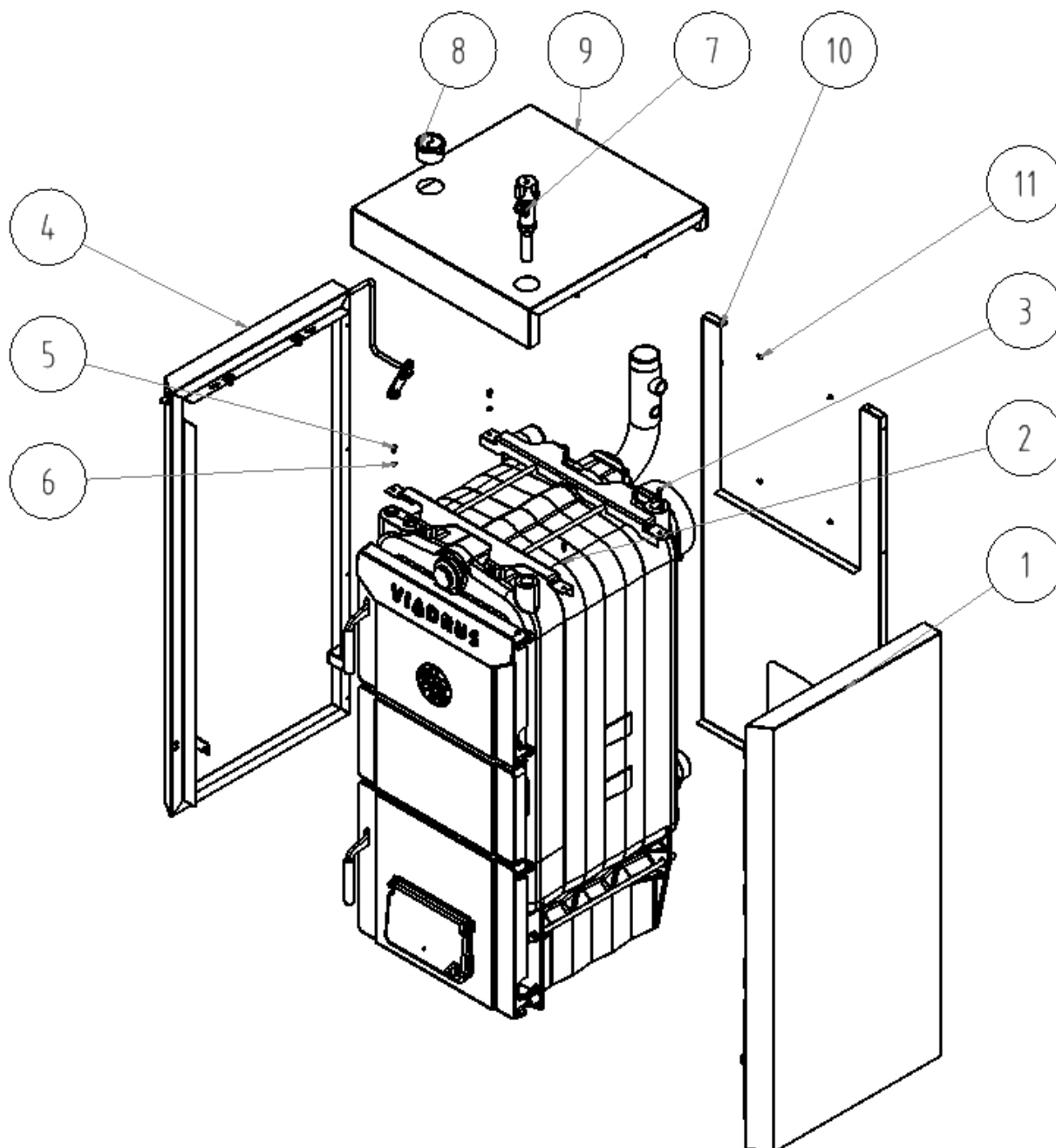

1. Right side part of the shell
2. Washer 5,3
3. Screw M5 x 10
4. Left side part of the shell
5. Screw M5 x 10
6. Washer 5,3

7. Draught controller
8. Thermomanometer
9. Upper part of the shell
10. Rear part of the shell
11. Screw ST 4,2 x 9,5

Fig. no. 16 Boiler shell

Mounting of draw bar of smoke flap control

1. Complete the smoke flap control according to the Fig.no.17.
2. Fasten the draw bar of the smoke flap control (2) to the smoke flap (1) by means of a lock 2,5 x 32 (3).
3. Screw the plastic ball M10 (4) on the front part of the draw bar
4. Stick the label of the smoke flap control.

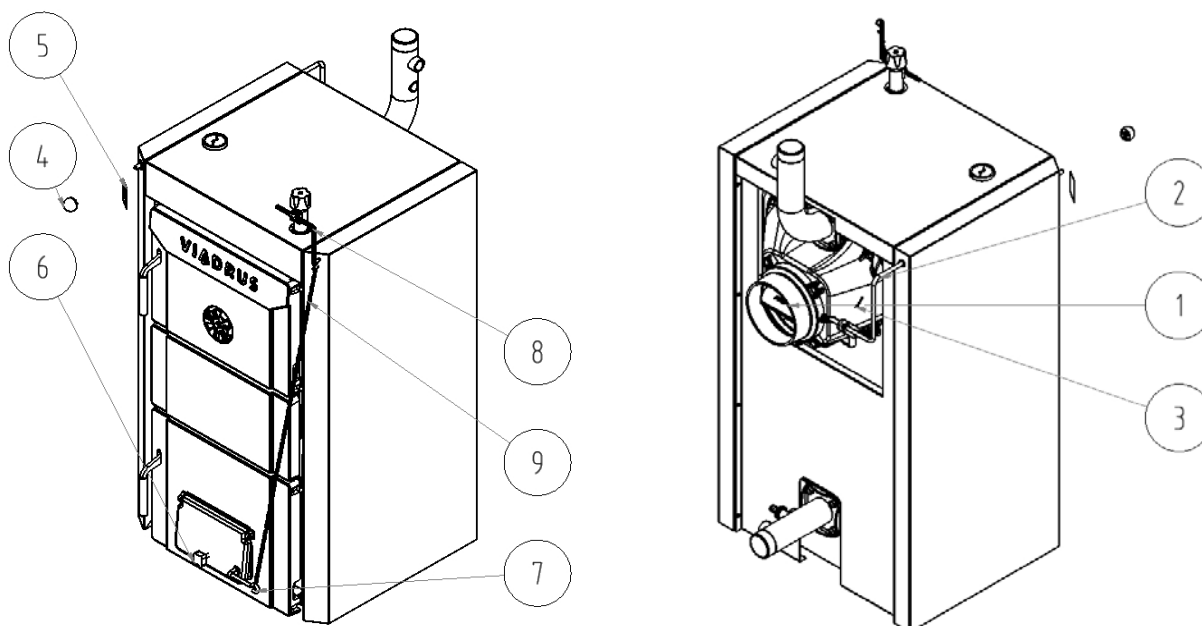

- | | |
|---------------------------------------|------------------------------------|
| 1. Smoke adapter with the smoke flap | 6. Choker screw |
| 2. Draw bar of the smoke flap control | 7. Suspension pin |
| 3. Lock 2,5 x 32 | 8. Lever of the draught controller |
| 4. Plastic ball M10 | 9. Chainlet |
| 5. Label of the smoke flap control | |

Fig.no.17 Smoke flap control

Draught regulator

The instructions for the draught regulator setting are given in the manual attached to the particular regulator.

Assembly tools for brush

Use the leather gloves and common assembly tools for mounting or dismounting of the brush and the spike point (if they are included in the delivery).

Filling the heating system with water:

The water hardness must correspond to ČSN 07 7401 and it is inevitable to treat the water according to Chap. no. 5.1. in case the water hardness is unsatisfactory.

The heating systems with an open expansion tank allow the direct contact between the heating water and the atmosphere. During the heating season the water expanding in the tank absorbs the oxygen, which increases its corrosive effects and at the same time the water evaporates heavily. Only the water treated to the values according to ČSN 07 7401 can be used for refilling.

The heating system must be thoroughly flushed out in order to wash out all impurities.

During the heating season it is necessary to keep a constant volume of heating water in heating system and be particular about bleeding the heating system to avoid the air suction into the system. Water from the boilers and heating system must never be discharged or taken for usage except in cases of emergency like the repairs etc. Water discharge and filling with new water increases the danger of corrosion and scale development. **In case we have to refill the heating system with water we only do this operation when the boiler is cold** in order to prevent its sections from getting broken.

After boiler and heating system refilling operation the all joints must be tested for tightness.

When using the two way safety vent DBV 1 - 02 the cooling water is added gradually to the to the reverse water.

The assembly and stoking test completion must be recorded in the "Guarantee certificate".

6. Commissioning

The boiler can only be commissioned by professional assembly firms authorized to do this activity.

6.1 Verification activities before commissioning

Before the boiler is put into operation it is necessary to check:

1. Filling the heating system with water (thermomanometer check) and the system tightness.
2. Connection to the chimney– **this connection can only be done with the agreement of a chimney-sweepers' firm (chimney revision) measure the chimney draught according to tab.no. 1,2,3 depending on particular fuel.**
3. Draught regulator and thermostatic valve functionality.

6.2 Boiler commissioning

1. Fire a boiler.
2. Bring the boiler to the necessary operating temperature. The recommended output water temperature is 80 °C.
3. Adjust the draught regulator incl. the chain length (according to enclosed draught regulator manual).
4. Check the functionality of protecting device against overheating (after-cooling loop or the two way safety vent DBV 1 - 02)
5. Operate the boiler in operating condition according to relevant standards.
6. Check again the boiler tightness.
7. Acquaint the user with operation.
8. Make a record in the Guarantee certificate.

7. Boiler operation by user

COKE

The most suitable fuel is the coke of 24 – 60 mm granularity.

HARD COAL

The most suitable fuel is the hard coal of 24 – 60 mm granularity

WOOD

The wood maximum moisture of 20% must be observed in order to achieve the rated boiler output.

The fuel must be stored under cover. The grate is cleaned in a way making sure that no glowing fuel gets through into the ash pan.

Recommended sizes of wooden blocks

number of sections	3	4	5	6	7	8	9	10
Blocks diameter [mm]	Ø 40 - 100							
Blocks length [mm]	300	300	350	400	500	600	700	800

Firing a boiler

1. Check on the thermomanometer the volume of water in the heating system.
2. Open the stop valve between the boiler and the heating system.
3. Clear the grate, the ash pan, smoke flues and the boiler walls. (after the clearing you must check the tightness in the smoke extension).
4. Through the ash pan door& the furnace door lay out the kindling and wood on the cleared grate within the whole depth of the boiler.
5. Bring the smoke shutter in the smoke extension/ adapter into the open position and close the stoking door.
6. Fire the kindling through the open ash pan and furnace door.
7. Shut the ash pan door& the furnace door and open fully the choker. At the 8 – 10 sectional boiler also the rear choker.

8. On the flaring wood load a thinner layer of basic fuel.
9. After its good ignition load other fuel up to the lower edge of the stoking door and level the fuel into a uniform layer along the whole depth of the boiler.
10. As soon as the fuel gets into a dark red glow by means of a tool open slightly the stoking door choker of the secondary air inlet at the stoking door.
11. After the flames get yellow close the stoking door choker of the secondary air inlet.

Operation

1. After having achieved the heating water temperature regulate the combustion air inlet. The boiler output is roughly regulated by the change in chimney draught by means of the smoke shutter in the smoke extension. The fine output regulation is done by means of the choker which regulates the air inlet under the grate either manually or by means of the draught regulator. The draught regulator must be set in a way making sure that the choker in the ash pan door is almost closed at the moment the heating water temperature has been achieved.
2. According to the heat need and the burning intensity the boiler must be refilled with fuel during the operation. Stoke in the way making sure that the fuel layer is evenly high along the whole depth of the boiler.
3. When using coke, hard coal and wood the stoking door choker at the secondary air inlet must be partially open during the whole time of gases and flames development from the freshly stoked fuel.
4. When switching over to the night inhibited operation clear the grate, let the freshly stoked fuel well burn up and then subdue the boiler output by throttling the chimney draught by means of the smoke throttle in the smoke extension and throttling the stoking door choker at the secondary air inlet. The degree of the smoke throttle and stoking door choker opening must be tested but it is necessary to be particular about no flue gases escaping into the boiler room. In this case the draught regulator has to be disconnected (the choker closed completely).
5. The boiler operation restoration in the morning is to be done by opening the smoke throttle and stoking door choker and poking the grate after the ash pan door opening.
6. The ash pan door must be permanently shut during the boiler operation.
7. According to the need clear the ash pan (it is necessary to use the gloves).
8. In case of use of stop valves the safety valve should be installed between the boiler and the stop valve.
9. We recommend cleaning the filter after the heating test and subsequently before the heating season.

8. IMPORTANT WARNING

1. **The boiler only can be used for the purpose that it is destined for.**
2. **The boiler only can be operated by adult persons who are familiar with this operation manual. In is inadmissible to leave the children at the boiler unattended by adults. The interferences with boiler that could endanger the health of operators or the roommates are impermissible.**
3. **The boiler is not destined for the use by persons (incl. children) whose physical, sensual or mental disability or lack of experience and knowledge prevent them from a safe use of the appliance unless they are supervised or if they were not instructed on the use of appliance by a person responsible for their safety.**
4. **Children should be supervised in order to ensure that they do not play with the appliance.**
5. **The boiler is not destined for the use by persons (incl. children) whose physical, sensual or mental disability or lack of experience and knowledge prevent them from a safe use of the appliance unless they are supervised or if they were not instructed on the use of appliance by a person responsible for their safety.**
6. **Children should be supervised in order to ensure that they do not play with the appliance.**
7. **If there occurs a danger of inflammable vapours and gases development and penetration into the boiler room or at works accompanied by temporary development of the fire or explosion danger (gluing of floor covering, painting with combustible painting colours), the boiler must be duly closed down before the works start.**
8. **It is FORBIDDEN to use flammable liquids for VIADRUS HERCULES U 26 boiler ignition.**
9. **During the operation it is FORBIDDEN to overheat the boiler.**
10. **On the boiler and within the distance shorter than the safe distance from it there must not be put any objects made of flammable materials.**

11. When clearing ashes at VIADRUS HERCULES U 26 boiler there must not be put any flammable materials within minimally 1500 mm distance from the boiler.
12. The space at the point of choking valve rotation of the ashtray door must be cleaned in case of clogging with fuel, ashes or other impurities in order to avoid its rubbing thus wrong functioning.
13. When operating the boiler at the temperature lower than 60 °C the boiler drum can get bedewed which means the low-temperature corrosion and reduction of boiler drum lifetime. Therefore we recommend to operate the boiler at the temperature of 60 °C and higher.
14. After the heating season termination it is necessary to clear thoroughly the boiler, smoke-flues and the smoke extension/ adaptor. Lubricate the pivots, the smoke throttle mechanism and other movable parts at the boiler with the graphite grease. Keep the boiler room clean and dry.
15. Possible corrosion marks on the boiler drum don't mean a defect and they do not affect the boiler function.
16. It is necessary to install a safety valve for maximum overpressure of 400 kPa on the system and its dimension must correspond to the rated boiler output. The safety valve must be located directly behind the boiler. Any stop valve must not be located between the safety valve and boiler. If you have any questions, please contact our contractual assembly firm and service organizations.

9. Maintenance

1. During the boiler operation remove the ashes from the ash pan several times a day depending on the kind of the used fuel, because the full ash pan prevents the combustion air from the proper distribution under the fuel and causes an uneven fire penetration through the fuel on the grate. We remove all remains from the combustion chamber, especially the clinker before every new firing and when restoring the boiler operation in the morning. The ashes must be put into fire-resistant covered containers. **Use the protective means at this work** and mind your personal safety.
2. When using the coke, hard coal and wood clear regularly once a month the walls of the boiler inside the combustion chamber 1x, the boiler smoke draughts and the smoke extension/ adaptor (this by means of a brush into the cooled down boiler where the temperature does not exceed 40 °C).
3. If in case of using the fuels with a more intensive gases development the tar deposit accumulates on the combustion chamber walls we remove it by means of a scraper or by burning dry hard wood (or coke) while bringing the boiler to the maximum working temperature.
4. After the heating season termination treat (by using the Vaseline) the pivots/ swivel pins of the smoke throttle and all doors.

10. Instructions for product disposal after its lifetime extinction

ŽDB GROUP a.s., is a contracting partner of the firm EKO-KOM a. s. with the client number EK-F00060715. The packages comply with EN 13427.

We recommend to dispose the packages in the way as follows:

- plastic foil, cardboard cover, use a salvage point
- metal strapping tape, use a salvage point
- wooden base, is designated for a single and no longer can be used as a product. Its disposal is subject to Act 477/2001 Coll. and 185/2001 Coll. as amended.

Because the product is constructed of common metal materials, we recommend to dispose individual parts as follows:

- the heat exchanger (grey cast-iron), use a salvage point
- distribution pipes, shell, use salvage point
- other metal parts, use a salvage point
- ROTAFLEX insulating material, through a firm engaged in waste collection and disposal

In case that the product has lost its manufacture qualities it can be taken advantage of the back collection service (if this is introduced); if the originator has declared that this is the waste and it will be handled according to the legislative provisions valid in the particular country.

11. Guarantee and reliability for defects

ŽDB GROUP a.s., VIADRUS division provides the guarantee:

- 24 months for boilers, this after the product was put into operation but maximum 30 months after the date it was dispatched from the manufacturing factory
- 5 years for a boiler drum, this after the date it was dispatched from the manufacturing factory

In case of possible complaint regarding the shell the customer is obliged to submit the packing label of the boiler shell. This is placed on the cardboard in which the shell has been dispatched.

The user is obliged to entrust a professional assembly firm with the commissioning and a contractual professional service accredited by ŽDB GROUP a.s., VIADRUS division, the manufacturer with the removal of faults. Otherwise the guarantee for boiler proper function does not apply. „VIADRUS HERCULES U 26 boiler quality and completeness certificate“ after its infilling serves as the „Guarantee certificate “.

A regular boiler maintenance must be done by its user.

Every notice of a fault must be conveyed immediately after its detection, always via a telephonic agreement and in writing.

If the above instructions are not observed the guarantees provided by the manufacturer will not be recognized.

The manufacturer reserves the right to make changes within the product innovations that needn't be included in this manual.

The guarantee does not apply to:

- the faults caused by a wrong assembly or wrong product operation and the faults caused by a wrong maintenance, see chapter 9.
- product damage arisen during the transport or other mechanical damage
- the faults caused by unsuitable storage
- the faults caused by the failure to observe the water quality in heating system, see chapter no.5.1 and 6.2 or by using the anti-freeze mixture
- the faults caused by the failure to observe the instructions stated in this manual

Information for customer

Packaging edentification	Assessment reference
PE Plastic sacks, folie, corrugated board, iron and plastic fix line	

Identification od principál materials used. Paper, Polyethylene, iron, wood

Part 1: Summary of assessment

Standard/Report	Assessment requirement	Claim	Note
1.1 Prevention by source reduction		YES	
1.2 Heavy metals and	ensure below maximum permitted levels for components (CR 13695-1:2000)	YES	
1.3 Other noxious/hazardous substances	ensure in compliance with (CR 13695-2:2002, EN 13428:2000)	YES	
2 Reuse	ensure reusability in all terms of the standard for the functional packaging unit (EN 13429:2000)	NO	
3.1 Recovery by material recycling	ensure recyclability in all term sof the standard for the functional packaging unit (EN 13430:2000)	YES	
3.2 Recovery in the form of energy	ensure that calorific gain is achievable for the functional packaging unit (EN 13431:2000)	YES	Iron - NO
3.3 Recovery by composting	ensure compost ability in all terms of the standard for the functional packaging unit (EN 13432:2000)	NO	

NOTE Conformity with EN 13427 requires affirmative responses to sections 1.1; 1.2; 1.3 and to at least one of 3.1; 3.2; 3.3. In addition, where a claim of reuse is made section 2 should also record affirmative responses.

Part 2: Statement of conformity

In the light of the assessment results recorded in part I above, this packaging is claimed to comply with the requirements of EN 13427:2000.

VIADRUS

ŽDB GROUP a.s. / závod VIADRUS

Bezručova 300 / 735 93 Bohumín / CZ

Tel.: +420 596 083 050 / Fax: +420 596 082 822

www.viadrus.cz / info@viadrus.cz